



Image shown might not reflect actual configuration

350ekW - 500ekW

60 Hz

	Standby	Prime
	350 ekW	320 ekW
	400 ekW	365 ekW
	450 ekW	410 ekW
	500 ekW	455 ekW

BENEFITS & FEATURES

CAT® GENERATOR SET PACKAGE

Cat generator set packages have been fully prototype tested and certified torsional vibration analysis reports are available. The packages are designed to meet the NFPA 110 requirement for loading, conform to the ISO 8528-5 steady state and fill transient response requirements.

CAT DIESEL ENGINES

The four-cycle Cat diesel engine combines consistent performance with excellent fuel economy and transient response that meets or exceeds ISO 8528-5. The engines feature a reliable, rugged, and durable design that has been field proven in thousands of applications worldwide in emergency standby installations.

COOLING SYSTEM

The cooling system has been designed and tested to ensure proper generator set cooling, and includes the radiator, fan, belts, and all guarding installed as standard. Contact your Cat dealer for specific ambient and altitude capabilities.

GENERATORS

The generators used on Cat packages have been designed and tested to work with the Cat engine. The generators are built with robust Class H insulation and provide industry-leading motor starting capability and altitude capabilities.

EMCP CONTROL PANELS

The EMCP controller features the reliability and durability you have to come to expect from your Cat equipment. The EMCP 4 is a scalable control platform designed to ensure reliable generator set operation, providing extensive information about power output and engine operation. EMCP 4 systems can be further customized to meet your needs through programming and expansion modules.

SPECIFICATIONS

ENGINE SPECIFICATIONS

Engine Model	Cat® C15 ACERT In-line 6, 4-cycle diesel
Bore x Stroke	137mm x 171mm (5.4in x 6.8in)
Displacement	15.2 L (928 in³)
Compression Ratio	16.1:1
Aspiration	Turbocharged Air-to-Air Aftercooled
Fuel Injection System	MEUI
Governor	Electronic ADEM™ A4
Emission Certifications	EPA TIER III

GENERATOR SET SPECIFICATIONS

Alternator Design	Brushless Single Bearing, 4 Pole
Stator	2/3 Pitch
No. of Leads	12
Available Voltage Options	600/480/440/240/220V
Frequency	60Hz
Alternator Voltage	24V
Alternator Insulation & IP	Class H; IP23
Standard Temperature Rise	125/130 Deg C
Available Excitation Options	Self-Excited, PMG
Voltage Regulation, Steady State +/-	≤1%

STANDARD EQUIPMENT

Air inlet system	Aftercooler core. Turbocharger
Control panels	EMCP4.2 control panel.
Cooling system	Coolant drain line with valve; terminated on edge of base. Fan and belt guards. Coolant Level Sensor Thermostats and housing, full open temperature 92 deg C (198 deg F). Coolant level sight gauge. Jacket water pump, gear driven, centrifugal. Caterpillar Extended Life Coolant.
Exhaust system	Exhaust manifold; dry.
Fuel system	Primary fuel filter w/integral water separator & secondary filter. Fuel cooler. Fuel priming pump. Flexible fuel lines. Engine fuel transfer pump
Generators and generator attachments	Brushless, self-excited 2/3 pitch, random wound. IP23 Protection. Insulation Class H and temperature rise Power centre, IP22 bottom cable entry Segregated low voltage wiring pane
Governing system	Cat Electronic Governor (ADEM A4).
Protection System	Safety Shutoff – High Water Temperature Safety Shutoff – Low Oil Pressure Safety Shutoff – Overspeed Coolant Level Sensor
Base / Fuel Tank	Narrow Skid Wide / Standard Sub Tank Base – UL & ULC Listed Integral Tank Base – UL & ULC Listed Spill Containment Overfill Prevention Valve
Starting/charging system	24-Volt Electric Starting Motor Charging Alternator
Certifications	EPA Stationary Emergency Use

OPTIONAL EQUIPMENT

Air inlet system	Single/Dual Element Air Cleaner Heavy Duty Air Cleaner
Control panels	EMCP 4.4 Local Annunciator Remote Annunciators Discrete I/O Module Device Server Volt Free Contact Earth (Ground) Fault Relay
Circuit Breakers	3-Pole 100% Rated – Single (Manual & Motorized). 3-Pole 100% Rated – Dual & Third (Manual). External Paralleling Auxiliary Contacts Neutral Bar
Enclosures	Sound Attenuated (SA). Weather Protective
Cooling system	Stone guards.
Mufflers	Industrial grade (10 dBA) Residential and Critical grade (25 dBA)
Base / Fuel Tank	Audio & Visual Fuel Alarm
Fuel System	Integral 670 Gal Tank Base Sub Tank Bases: 660, 1000, 1900, 2200 Gal
Generators and generator attachments	Excitation – Self Excitation – Internal / AREP / PMG Oversize Coastal Protection (CIP) Space Heater Control
Starting/charging system	Standard Battery Set Oversize Battery Set.
Certifications	UL2200 Listed CSA 22.2 Certification of Compliance – IBC Seismic Certification of Compliance – IBC Seismic and OSHPD
General	Tool Set.

WEIGHTS & DIMENSIONS

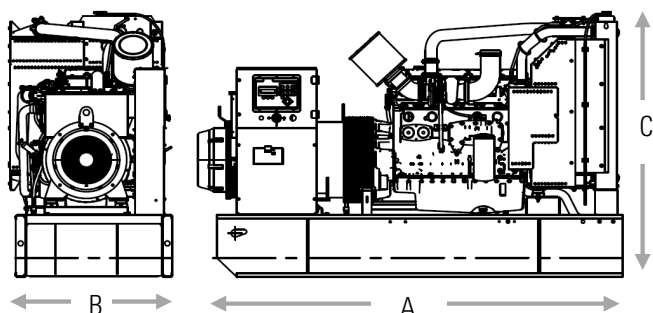

Standby Ratings	Dim "A" mm (in)	Dim "B" mm (in)	Dim "C" mm (in)	Generator Set Weight kg (lb)
350 ekW	3476 (137)	1628 (64)	2128 (84)	3939 (8683)
400 ekW	3476 (137)	1628 (64)	2128 (84)	4066 (8963)
450 ekW	3476 (137)	1628 (64)	2128 (84)	4115 (9071)
500 ekW	3476 (137)	1628 (64)	2128 (84)	4365 (9623)



Image shown might not reflect actual configuration

INTEGRAL & SUB BASE FUEL TANKS

FEATURES

- UL Listed for United States (UL 142) and Canada (CAN/ULC S601)
- Facilitates compliance with NFPA 30 code, NFPA 37 and 110 standards and CSA C282 code
- Dual wall
- Lockable fuel fill cap, 4" (101.6 mm) NPT
- Low fuel level warning standard, customer configurable warning or shutdown
- Primary tank leak detection switch in containment basin
- Tank design provides capacity for thermal expansion of fuel
- Fuel supply dip tube is positioned so as not to pick up fuel sediment.
- Fuel return and supply dip tube is separated by an internal baffle to prevent immediate re-supply of heated return fuel
- Pressure washed with an iron phosphate solution
- Interior tank surfaces coated with a solvent-based thin-film rust preventative
- Heavy gauge steel gussets with internal lifting rings
- Primary and secondary tanks are leak tested at 20.7 kPa (3 psi) minimum
- Compatible with open packages and enclosures
- Gloss black polyester alkyd enamel exterior paint
- Welded steel containment basin (minimum of 110% of primary tank capacity)
- Direct reading fuel gauge with variable electrical output
- Emergency vents on primary and secondary tanks are sized in accordance with NFPA 30
- Rear stub-up access

SUB BASE

- The sub-base fuel tank mounts below the generator set wide base

INTEGRAL

- Integral diesel fuel tank is incorporated into the generator set base frame
- Robust base design includes linear vibration isolators between tank base and engine generator.

OPTIONS

- Audio/visual fuel level alarm panel
- 5gal (18.9 L) spill containment
- 5gal (18.9 L) spill containment with fuel fill drop tube with in 6" (152 mm) from bottom of tank
- 5gal (18.9 L) spill containment with overflow prevention valve and fuel fill drop tube with in 6" (152 mm) from bottom of tank
- ULC Listed 7.5gal (28.4 L) spill containment with vent extensions, vent whistle, and drop tube facilitating compliance with CSA B139-09
- ULC Listed 7.5gal (28.4 L) spill containment with overflow prevention valve, vent extensions, vent whistle and drop tube facilitating compliance with CSA B139-09

Integral & Sub-Base Fuel Tank Base Useable Capacities with Fuel Tank Dimensions & Weights

Integral – Width (W) 2014 mm (79.3 in)

Sub-base – Width (W) 2056 mm (81.0 in)

A. Open Set & Weather Protective Enclosure

C15 Tank Design	Feature Code	Total Capacity		Useable Capacity		Tank Only						Overall Package Height with Tank			
		Liter	Gallon	Liter	Gallon	Dry Weight		Height 'H'		Length 'L'		Open		Enclosure	
						kg	lb	mm	in	mm	in	mm	in	mm	in
Integral	FTDW002	1283	339	1262	333	1015	2237	635	25.0	3814	150.1	2426	95.5	2619	103.0
Sub-Base	FTDW005	3941	1041	3876	1024	1659	3657	635	25.0	5550	218.5	2763	108.8	2955	116.3
Sub-Base	FTDW006	6980	1844	6818	1801	2228	4483	889	35.0	6184	243.5	3017	118.8	3209	126.3
Sub-Base	FTDW008	2476	654	2435	643	1468	3236	635	25.0	3810	150.0	2763	108.8	2955	116.3

B. Sound Attenuated Enclosure

C15 Tank Design	Feature Code	Total Capacity		Useable Capacity		Tank Only						Overall Package Height with Tank			
		Liter	Gallon	Liter	Gallon	Dry Weight		Height 'H'		Length 'L'		Open		Enclosure	
						kg	lb	mm	in	mm	in	mm	in	mm	in
Integral	FTDW001	1283	339	1262	333	1015	2237	639	25.0	4746	186.9	NA	NA	2619	103.0
Sub-Base	FTDW005	3941	1041	3876	1024	1659	3657	635	25.0	5550	218.5	NA	NA	2955	116.3
Sub-Base	FTDW006	6980	1844	6818	1801	2228	4483	889	35.0	6184	243.5	3017	118.8	3209	126.3
Sub-Base	FTDW011	2476	654	2435	643	1468	3236	635	25.0	3810	150.0	NA	NA	2955	116.3

C. Estimated Run Times (Hours) at 100% Load

C15 Tank Design	Feature Code	Standby Ratings (ekW)		Prime Ratings (ekW)	
		400	350	350	320
Integral Tank	FTDW001 / FTDW002	9	9	11	11
Sub-Base	FTDW005	28	29	32	36
Sub-Base	FTDW006	57	63	62	67
Sub-Base	FTDW008 / FTDW011	17	18	20	22

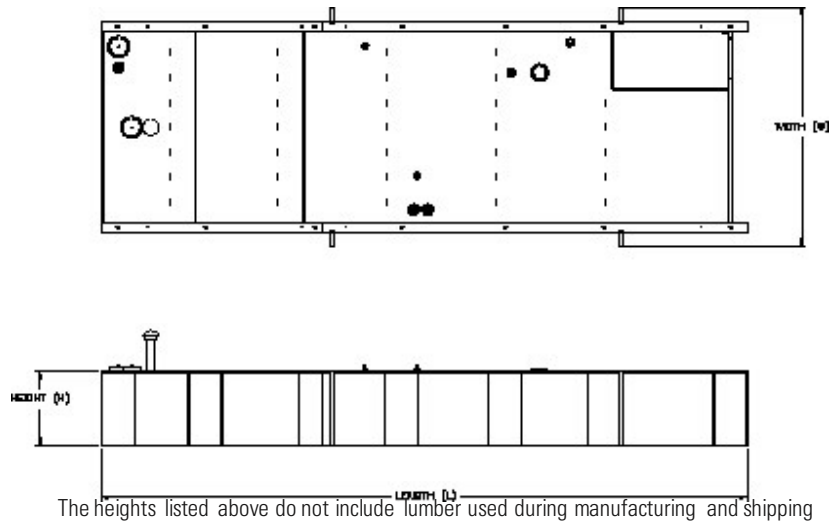

Tanks with full electrical stub-up area include removable end channel. Tanks with RH stub-up include stubup area directly below the circuit breaker or power terminal strips. Dimensions include weather-protective enclosure exhaust system.

Dual wall sub-base tanks are UL Listed and constructed in accordance with UL Standard for Safety UL 142, Steel Aboveground Tanks for Flammable and Combustible Liquids and Canada CAN/ULC S601, Standard for Shop Fabricated Steel Aboveground Horizontal Tanks for Flammable and Combustible Liquids.

Fuel tanks and applicable options facilitate compliance with the following United States NFPA Code and Standards:

NFPA 30: Flammable and Combustible Liquids Code

NFPA 37: Standard for the Installation and Use of Stationary Combustion Engines and Gas Turbines

NFPA 110: Standard for Emergency and Standby Power Systems

Fuel tanks and applicable options facilitate compliance with the following Canadian Standard and Code:

CSA C282 – Emergency Electrical Power Supply for Buildings

CSA B139-09 – Installation Code for Oil-Burning Equipment

The following sub-base fuel tanks meet Chicago code for containment and labelling:

FTDW005

FTDW008

FTDW011



Image shown might not reflect actual configuration

SOUND ATTENUATED ENCLOSURES

60 Hz

FEATURES

Robust / Highly Corrosion Resistant Construction

- Factory installed on skid base
- Environmentally friendly, polyester powder baked paint
- 14 gauge steel.
- Interior zinc plated fasteners
- Exterior stainless steel fasteners
- Internally mounted exhaust silencing system
- Designed and tested to comply with UL 2200 Listed generator set package
- Compression door latches providing solid door seal

Excellent Access

- Large cable entry area for installation ease
- Accommodates side mounted single or multiple breakers
- Three doors on both sides
- Vertically hinged allow 180° opening rotation and retention with door stays
- Lube oil and coolant drains piped to the exterior of the enclosure base
- Radiator fill cover

Security and Safety

- Lockable access doors which give full access to control panel and breaker
- Cooling fan and battery charging alternator fully guarded
- Fuel fill, oil fill and battery can only be reached via lockable access
- Externally mounted emergency stop button
- Designed for spreader bar lifting to ensure safety
- Stub-up area is rodent proof

Transportability

- These enclosures are of extremely rugged construction to withstand outdoor exposure and rough handling common on many construction sites.

Options

- Enclosure constructed with 14 gauge steel
- Enclosure constructed with 12 gauge aluminum (5052 grade)
- Caterpillar yellow or white paint
- Control panel viewing window
- UL Listed integral fuel tank with 670, 400, and 300 gallon capacities
- UL Listed sub base fuel tank with 660, 1000, 1900, and 2200 gallon capacities.
- Seismic certification per applicable building codes: IBC 2000, IBC 2003, IBC 2006, IBC 2009, IBC 2012, CBC 2007, CBC 2010
- IBC Certification for 150 mph wind loading
- AC/DC lighting package
- 5 kW Canopy space heater to facilitate compliance with NFPA 110
- Motorized louvers and gravity discharge damper
- 125A Load Center
- GFCI outlets

Enclosure Package Operating Characteristics

Enclosure Type	Standby ekW	Cooling Air Flow Rate		Ambient Capability*		Sound Pressure Levels (dBA) at 7m (23 ft)
		m ³ /s	cfm	°C	°F	100% Load
Level 1 Sound Attenuated Enclosure (Steel)	350	10.4	22072	59	138	73
	400	10.4	22072	51	124	73
	450	10.4	22072	46	115	74
	500	12.5	26415	48	118	75
Level 2 Sound Attenuated Enclosure (Steel)	350	10.4	22071	50	122	72
	400	10.4	22071	50	122	72
	450	10.4	22071	50	122	72
	500	12.5	26415	50	122	72
Sound Attenuated Enclosure (Aluminum)	350	10.4	22072	59	138	72
	400	10.4	22072	51	124	73
	450	10.4	22072	46	115	74
	500	12.5	26415	48	118	75

*Cooling system performance at sea level. Consult your Cat® dealer for site specific ambient and altitude capabilities.

Note: Sound level measurements are subject to instrumentation, installation and manufacturing variability, as well as ambient site conditions.

Component Weights to Calculate Package Weight

Standby ekW	Narrow Skid Base		Wide Skid Base		Sound Attenuated Enclosure (Steel)		Sound Attenuated Enclosure (Aluminum)	
	kg	lb	kg	lb	kg	lb	kg	lb
350 400 450 500	273	602	465	1025	1245	2745	765	1687

DIMENSIONS

Enclosure Type	Standby Ratings, kW	Length, L		Width, W		Height, H	
		mm	in	mm	in	mm	in
Sound Attenuated Enclosure on Skid Base	350	4948	194.8	2014	79.3	2320	91.3
	400						
	450						
	500						
Sound Attenuated Enclosure on a UL Listed Integral Fuel Tank Base	350	4948	194.8	2014	79.3	2619	103.0
	400						
	450						
	500						
Sound Attenuated Enclosure on a UL Listed 660 Gallon Sub-Base Fuel Tank Base	350	4948	194.8	2056	80.9	2955	116.3
	400						
	450						
	500						
Sound Attenuated Enclosure on a UL Listed 1000 Gallon Sub-Base Fuel Tank Base	350	5751	226.4	2056	80.9	2955	116.3
	400						
	450						
	500						
Sound Attenuated Enclosure on a UL Listed 1900 Gallon Sub-Base Fuel Tank Base	350	6382	251.2	2056	80.9	3209	126.3
	400						
	450						
	500						

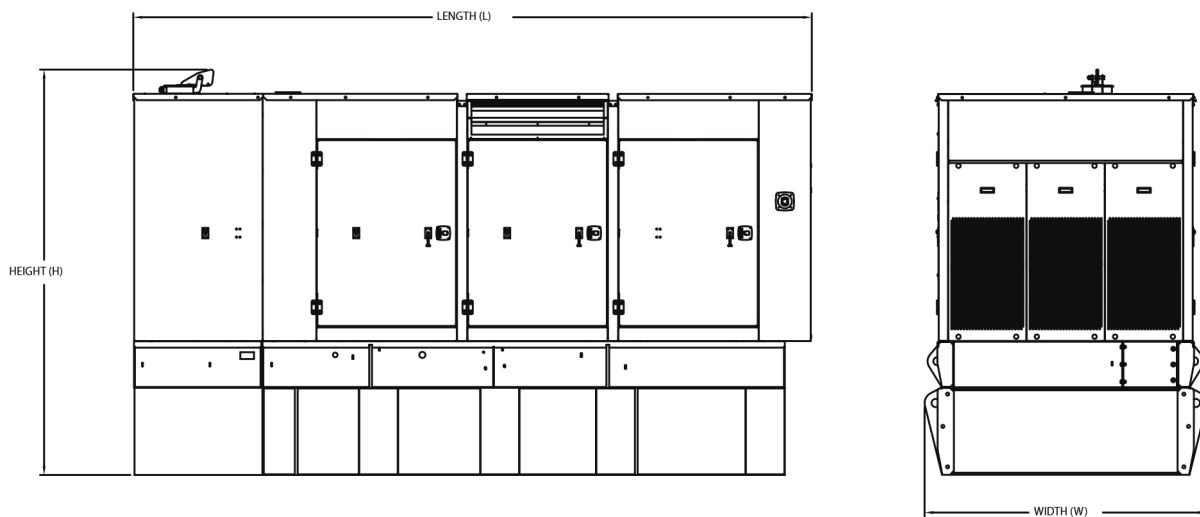

EMCP 4 CONTROL KEY FEATURES

EMCP 4 control features

- Run / Auto / Stop Control
- Speed and Voltage Adjust
- Engine Cycle Crank
- 24-volt DC operation
- Environmental sealed front face
- Text alarm/event descriptions

Digital indication for:

- RPM
- DC volts
- Operating hours
- Oil pressure (psi, kPa or bar)
- Coolant temperature
- Volts (L-L & L-N), frequency (Hz)
- Amps (per phase & average)
- kW, kVA, kVAR, kW-hr, %kW, PF (4.2 only)

Warning/shutdown with common LED indication of:

- Low oil pressure
- High coolant temperature
- Overspeed
- Emergency Stop
- Failure to start (overcrank)
- Low coolant temperature
- Low coolant level



Programmable protective relaying functions:

- Generator phase sequence
- Over/Under voltage (27/59)
- Over/Under Frequency (81 o/u)
- Reverse Power (kW) (32) (4.2 only)
- Reverse reactive power (kVAr) (32RV)
- Overcurrent (50/51)

Communications:

- 4 digital inputs & 4 relay outputs (4.1)
- 6 digital inputs & 8 relay outputs (4.2)
- 12 digital inputs & 8 relay outputs (4.4)
- Customer data link (Modbus RTU) (4.2 only)
- Accessory module data link (4.2 only)
- Serial annunciator module data link (4.2 only)
- Emergency stop pushbutton

Compatible with the following:

- Digital I/O module
- Local Annunciator
- Remote CAN annunciator
- Remote serial annunciator

FINANCING

Caterpillar offers an array of financial products to help you succeed through financial service excellence. Options include loans, finance lease, operating lease, working capital, and revolving line of credit. Contact your local Cat dealer for availability in your region.

WORLDWIDE PRODUCT SUPPORT

Cat dealers provide extensive post-sale support including maintenance and repair agreements. Cat dealers have over 1,800 dealer branch stores operating in 200 countries. The Caterpillar® SOSSM program effectively detects internal engine component condition, even the presence of unwanted fluids and combustion by-products.

LET'S DO THE WORK.™